

Aventuras de YAMI

CECILIO AVILÉS

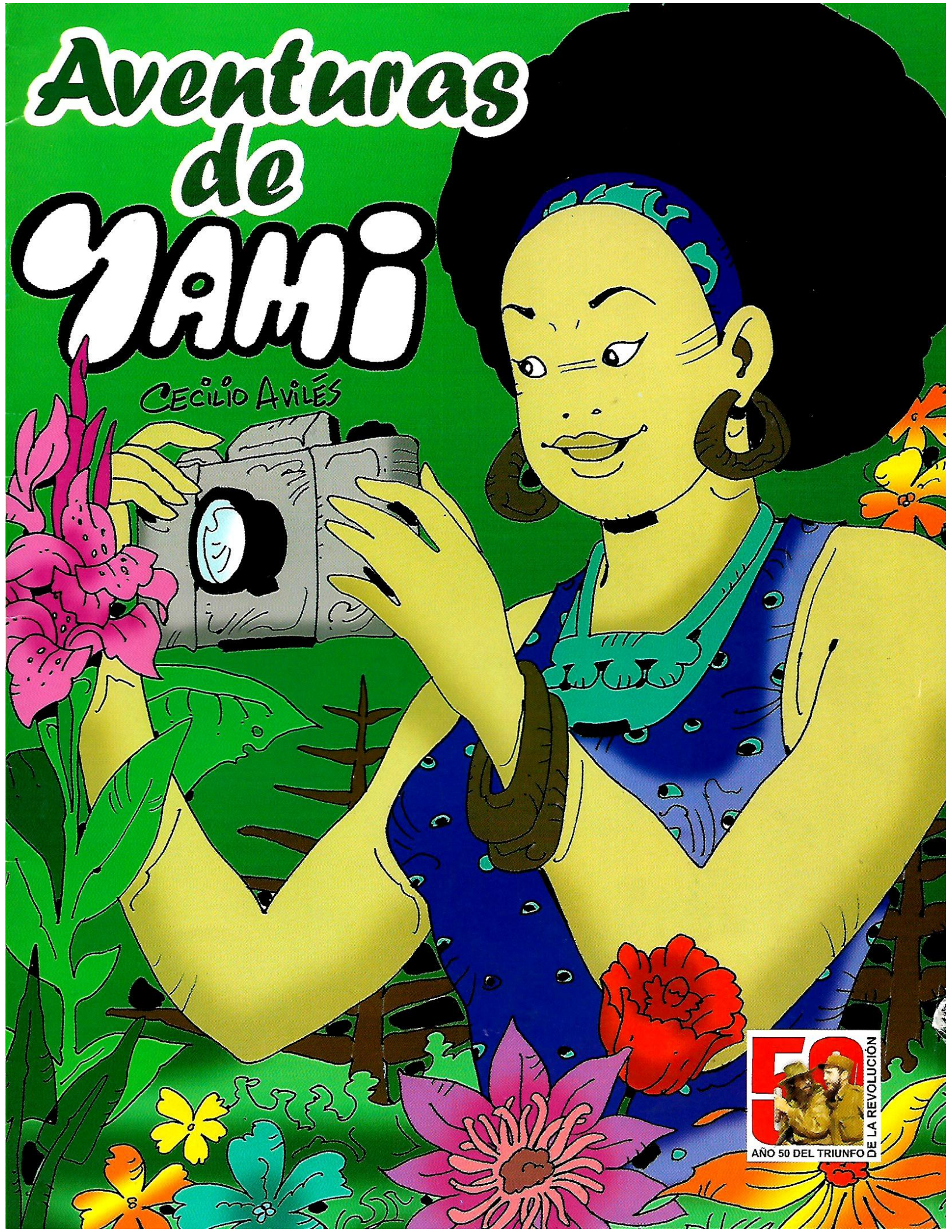

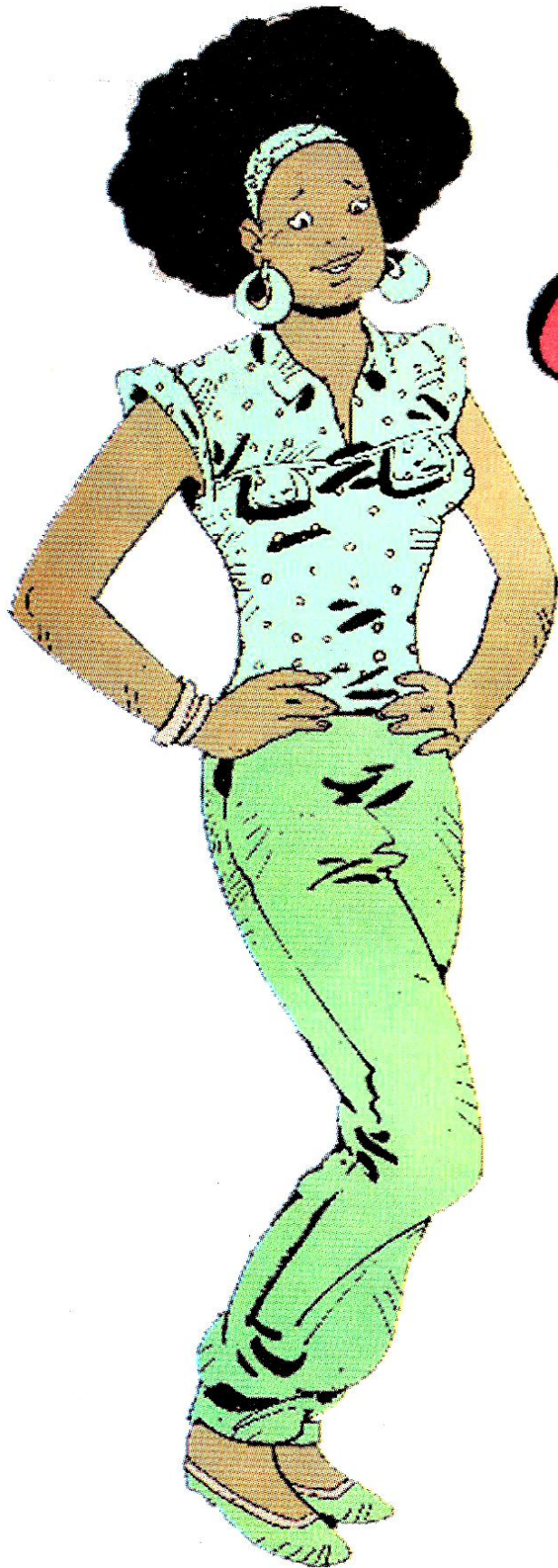

Aventuras de **YAMI**



Pablo de la Torriente
Editorial

Edición: Manuel Pérez Alfaro
Ilustraciones: Cecilio Avilés Montalvo
Realización: Alejandro F. Romero Ávila
Diseño de Cubierta: Rafael López Viera
Producción: Vladimir Latour Morales

© Cecilio Avilés Montalvo, 2008

© Pablo de la Torriente, Editorial
Calle 11 no. 160 e/ K y L, Vedado,
La Habana, Cuba. CP 10400,
Teléf.: 832-7581 al 83
c.e: edpablo@eventos.cip.cu
cip331@enet.cu

ISBN: 978-959-259-303-9



Prohibida la reproducción parcial o total de la obra sin el consentimiento expreso del autor.

Aventuras de **YAMI**

CECILIO AVILÉS

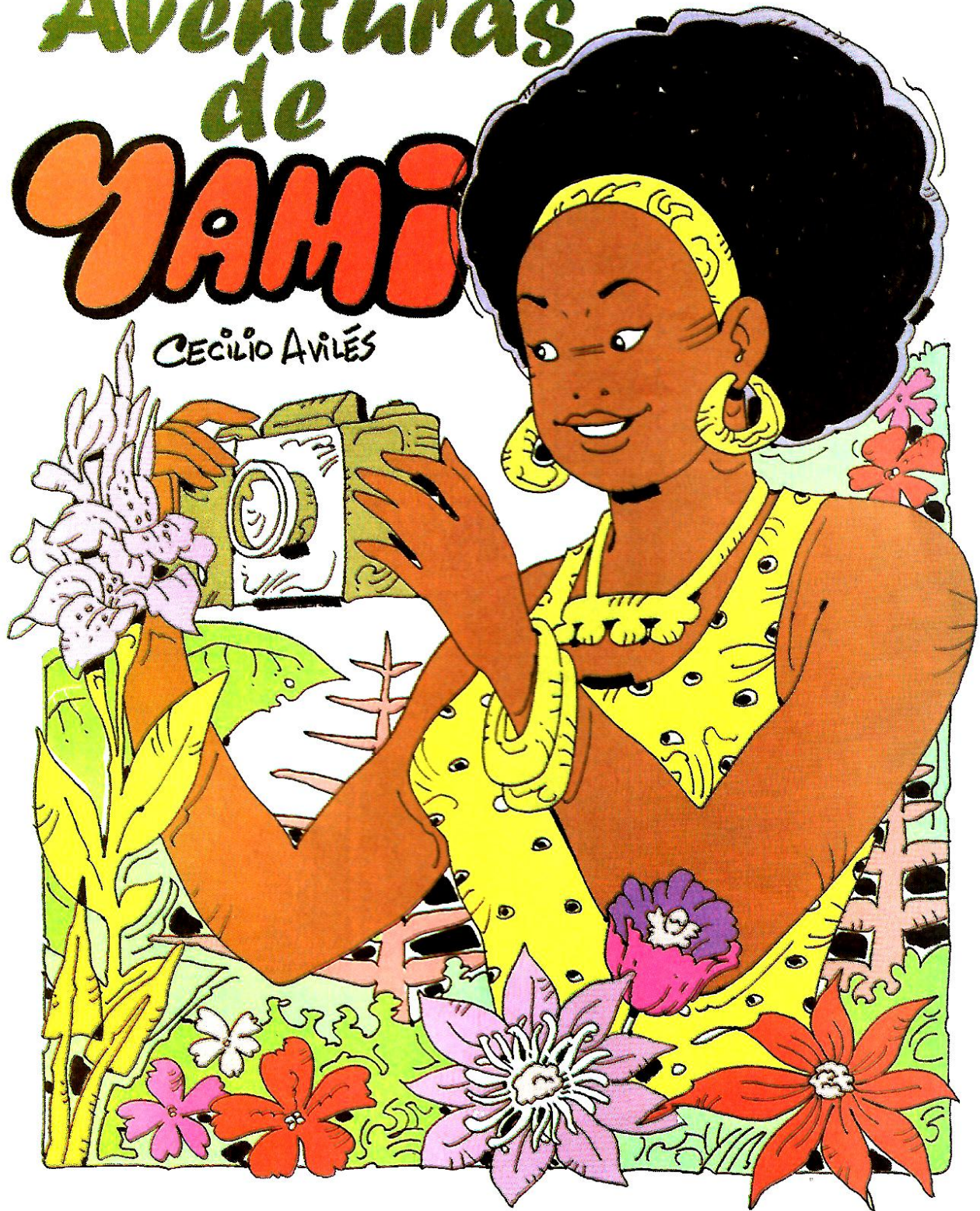

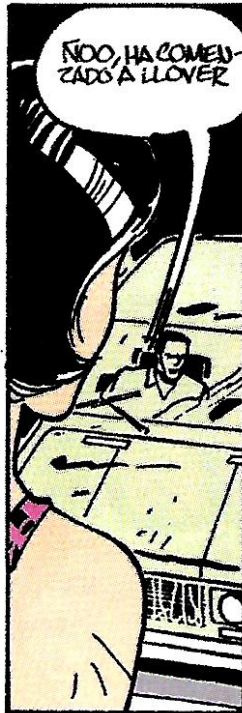
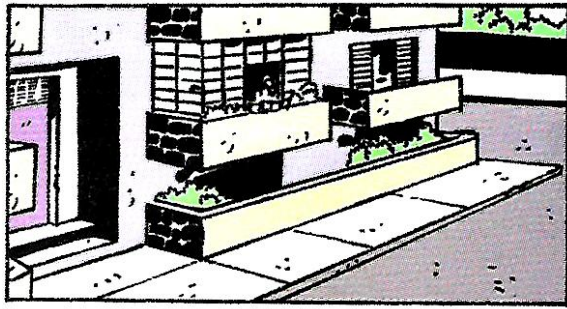

NOO, HA COMENZADO A LLOVER



CIERZA LA VENTANILLA, ASI NADIE PODRA ESCUCHAR LO QUE HABEMOS



QUE TIPOS MAS EXTRAÑOS

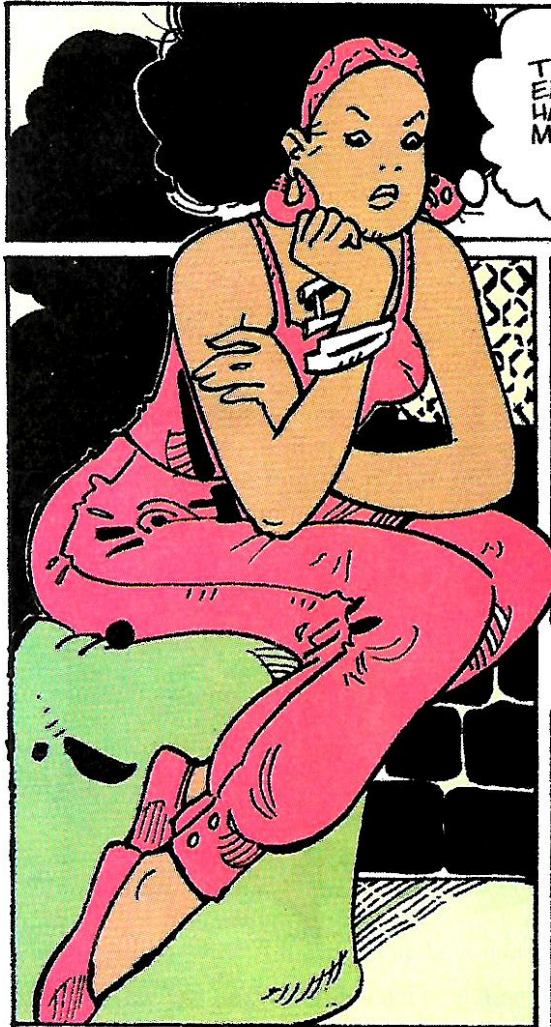

TREMENDO EMBARQUE ME HA DADO MI MAMA...

YAMI

GUIÓN Y DIBUJO: CECILIO ANILÉS



... AHORA NO SE QUE HACER ...



YAMI, ¿QUE TE OCURRE?

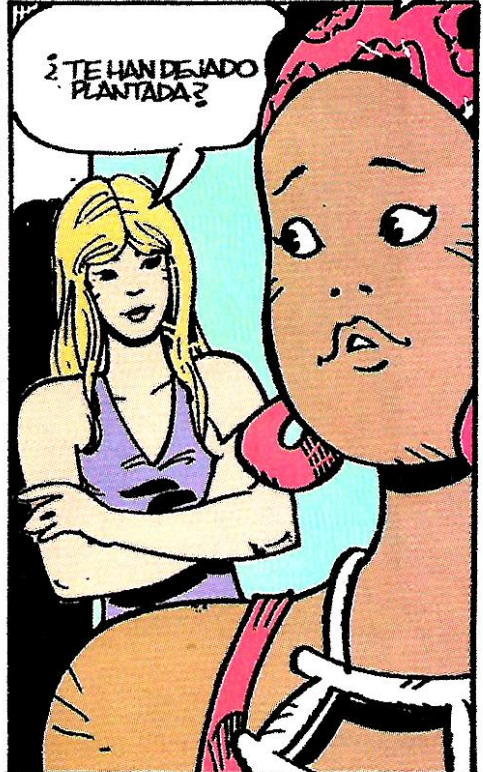

¿TE HAN DEJADO PLANTADA?

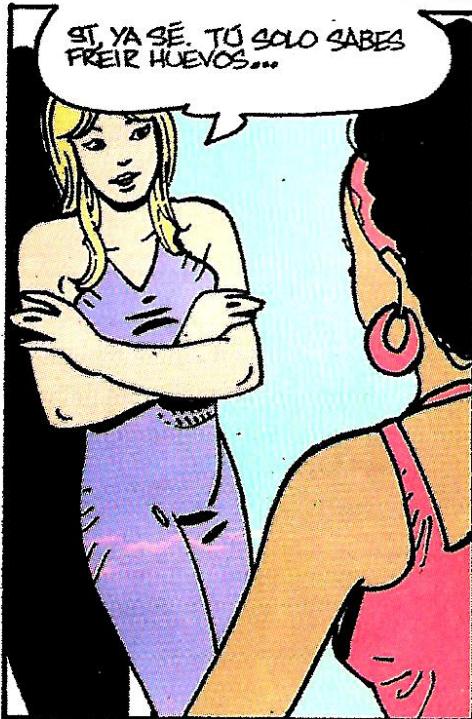

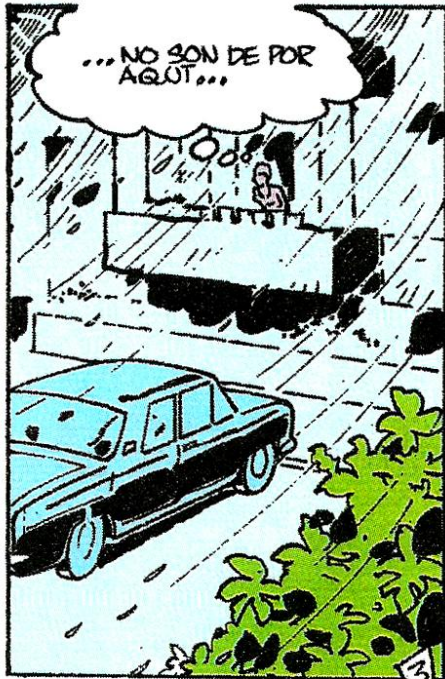

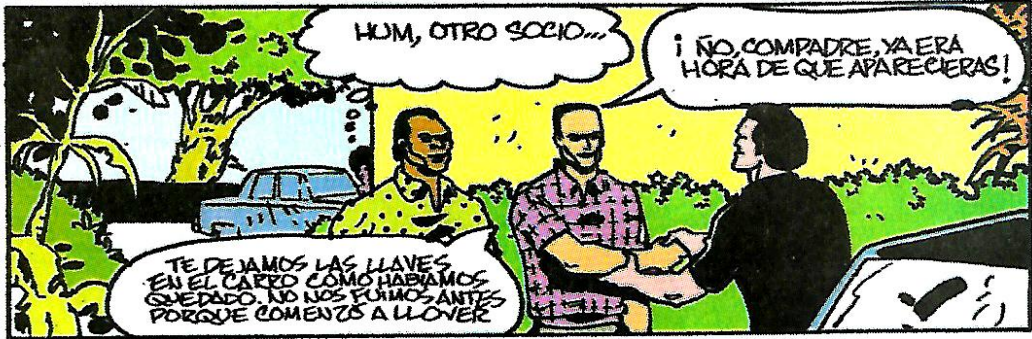
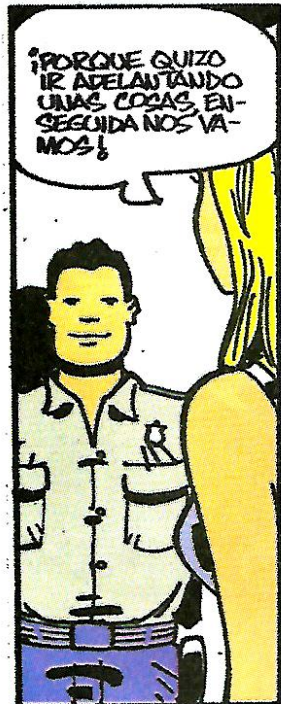

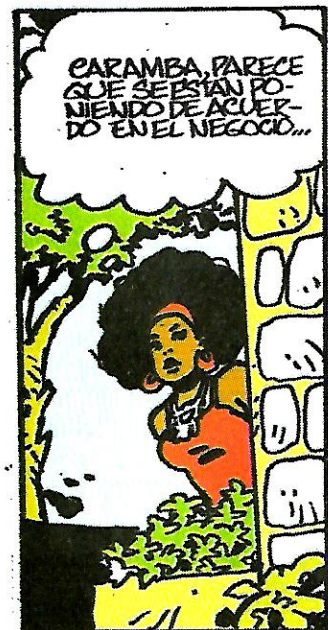
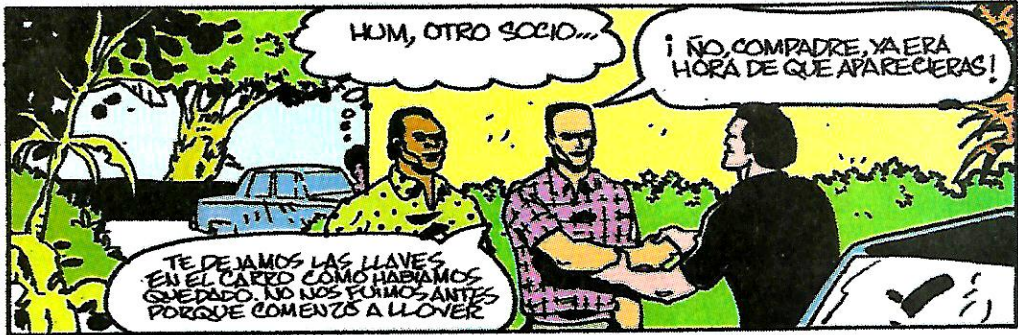
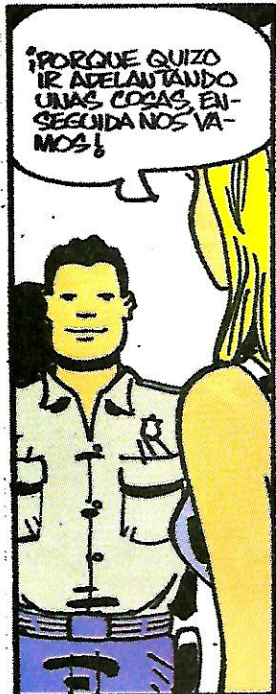
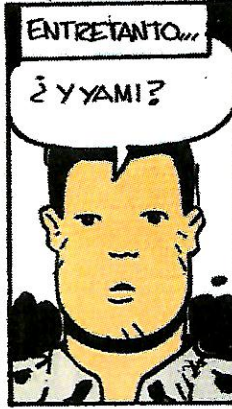

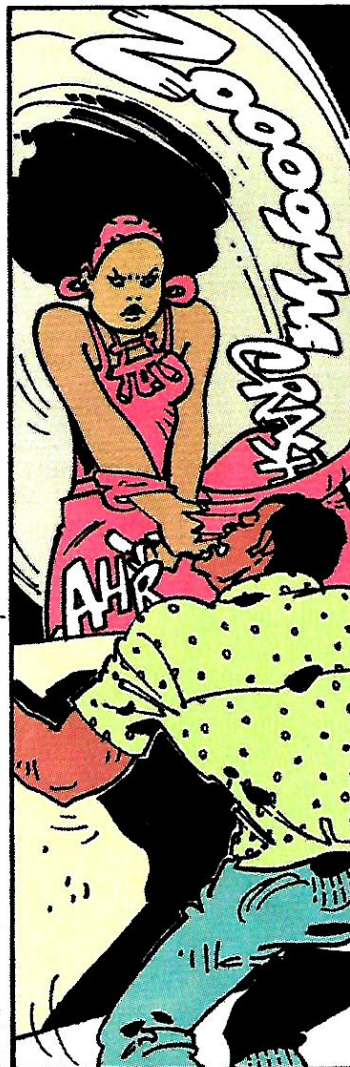

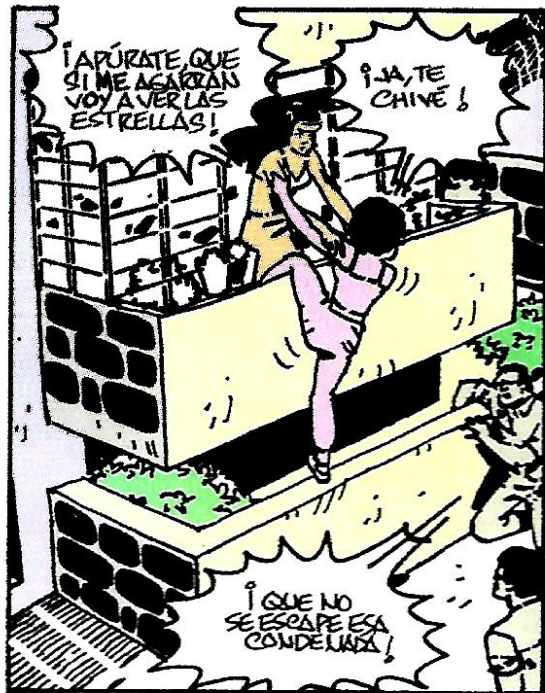





FIN



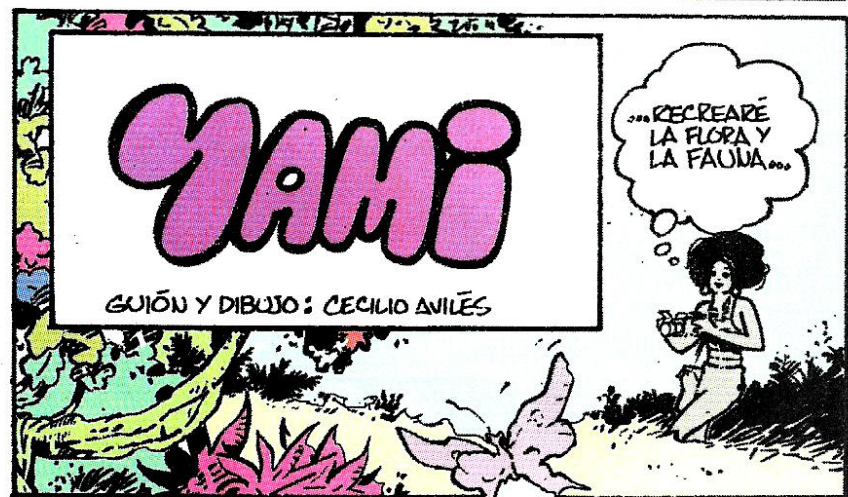
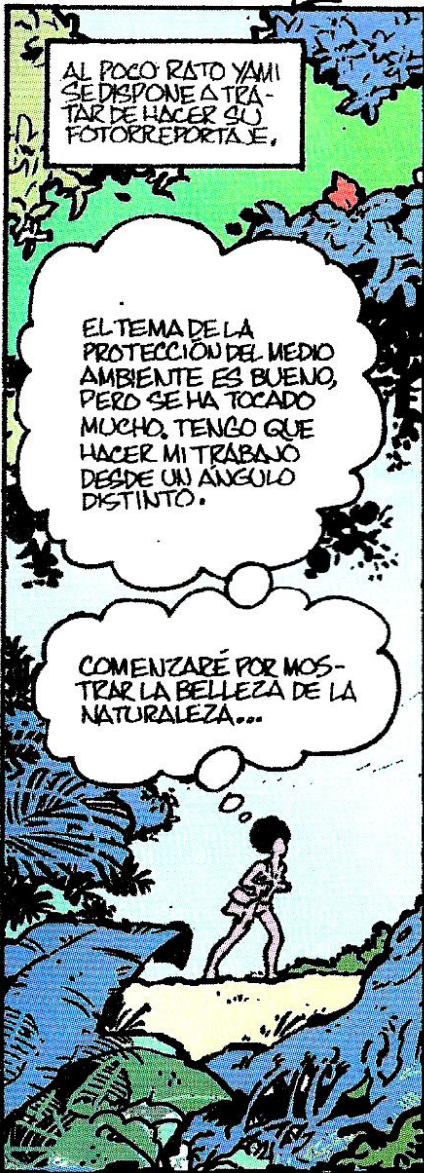

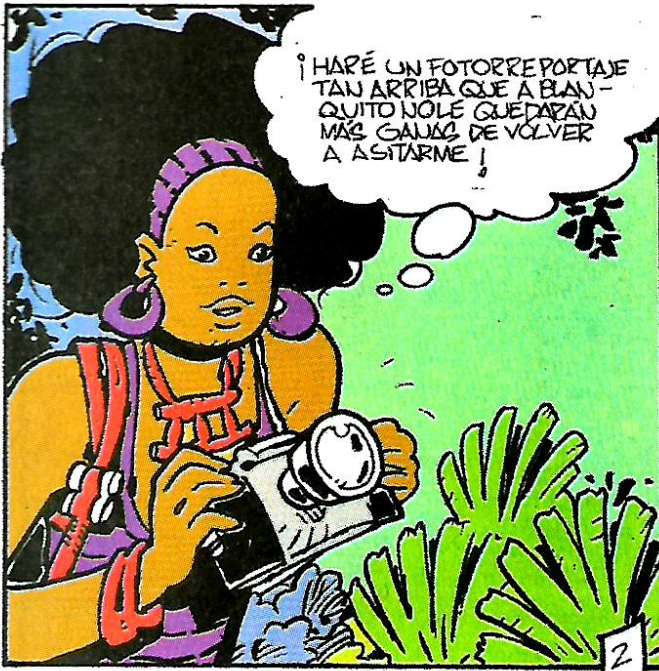



OYE, ESA MUJERCHA
NOSTIRO UNAS FOTO:...



BUENO, CREO QUE CON ESAS FOTOS DE
LOS TIPOS ARROJANDO BASURAS EN EL RIO
TENGO CUADRADO MI REPORTAJE...



...DEMOSTRARE COMO LA FABRICA
Y OTROS ELEMENTOS AFECTAN
AL RIO Y LA FLORA CERCA DEL...



NO LA
PIERDAS DE
VISTA.

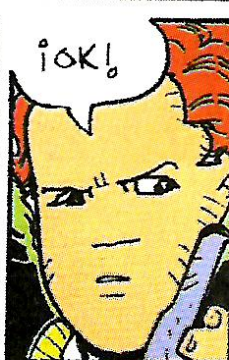

¡OK!



...POR SI ACASO ES
MEJOR SACAR TODA
LA "CARGA" QUE NOS
QUEDA EN LA FABRI-
CA MAÑANA MISMO.



¡ES MUCHO LO QUE ESTA
EN JUEGO. NO PODEMOS
DEJARLA IR CON ESAS
FOTOS QUE NOSTIROS!

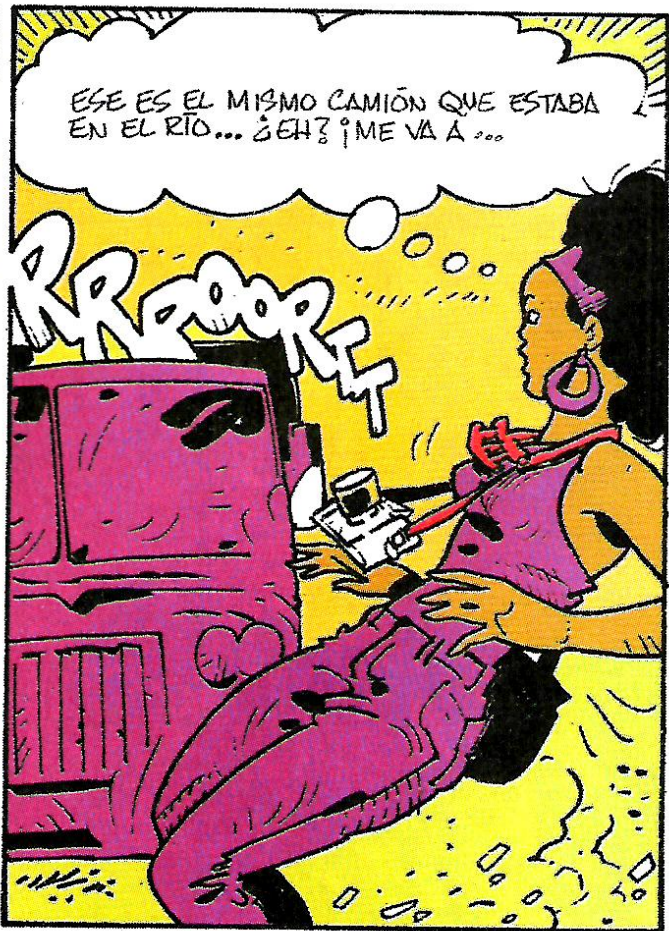

ESE ES EL MISMO CAMION QUE ESTABA
EN EL RIO... ¿EH? ¡ME VA A ...

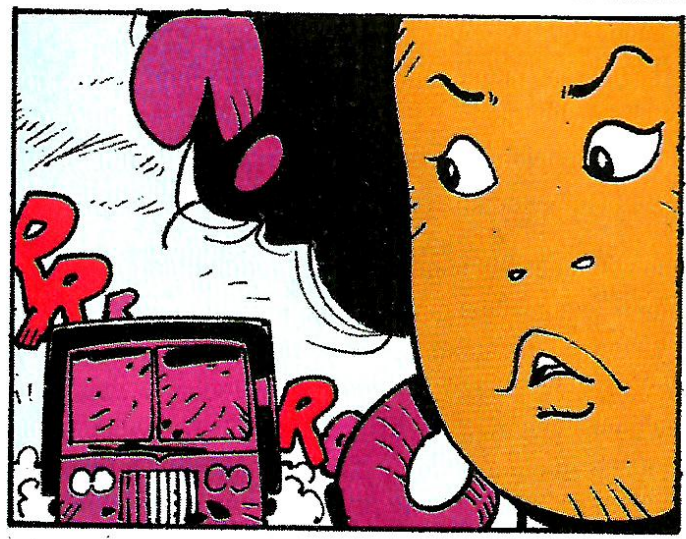

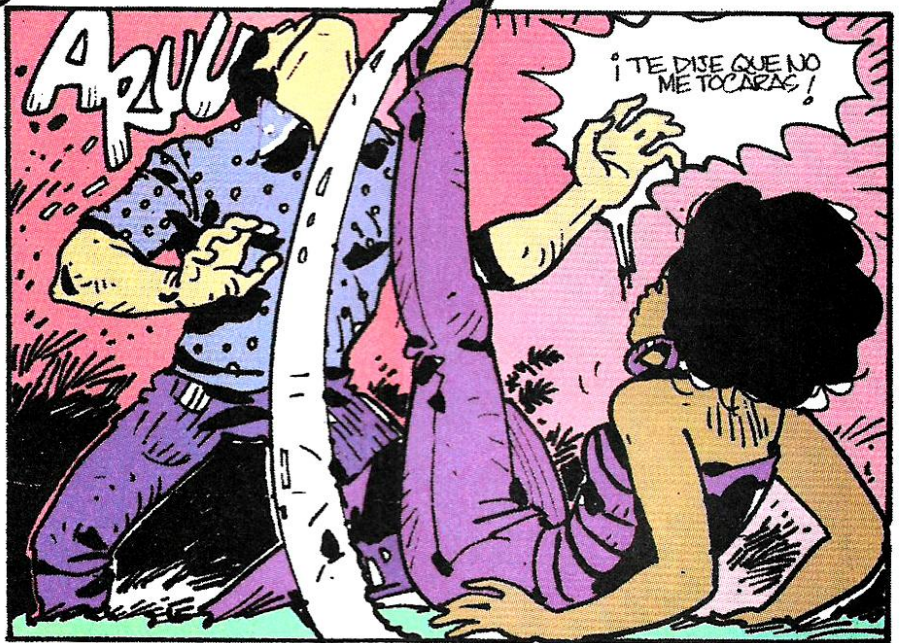



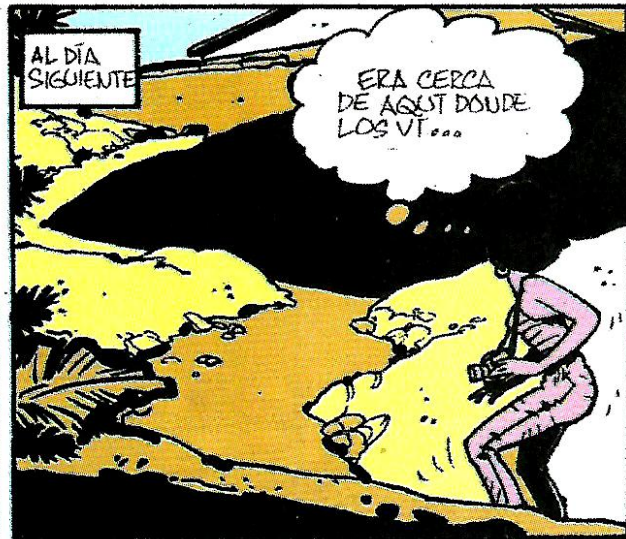
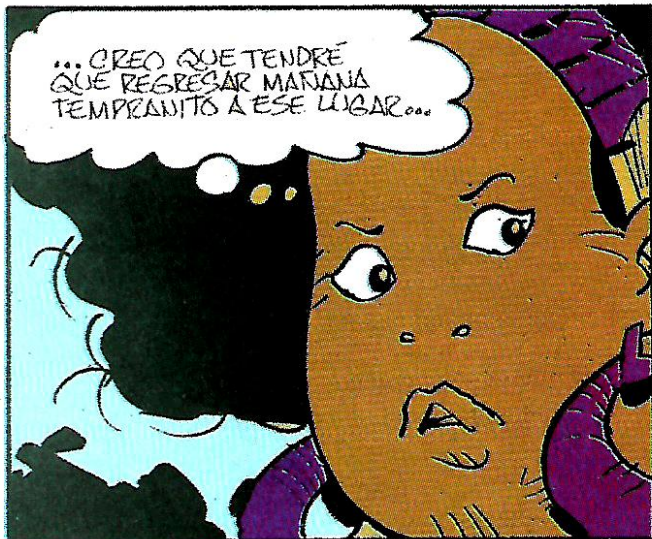
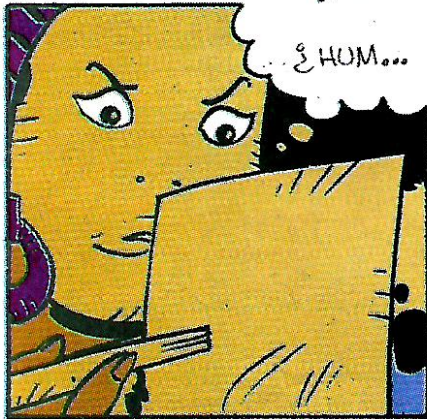

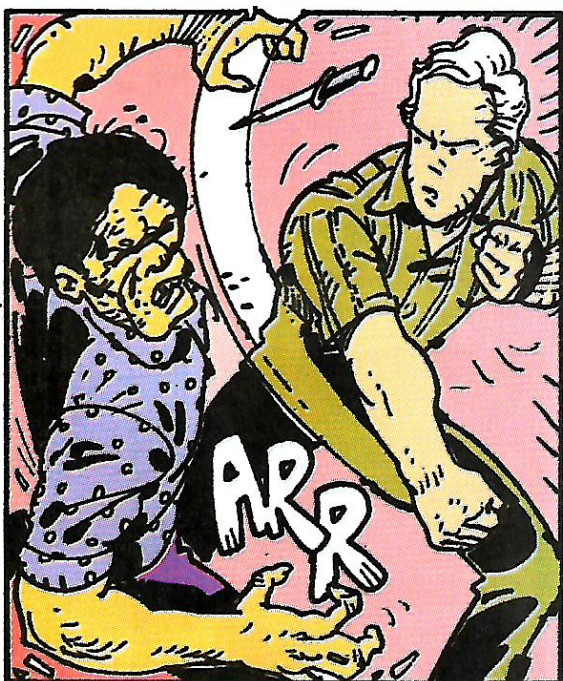

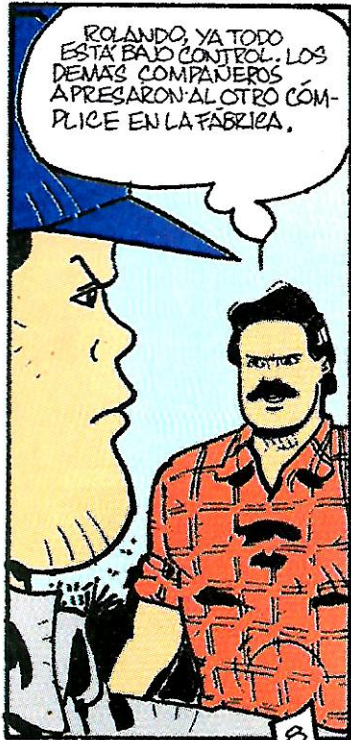

ROLANDO, YA TODO ESTÁ BAJO CONTROL. LOS DEMÁS COMPAÑEROS APRESARON AL OTRO CÓMPlice EN LA FÁBRICA.



ERA EL ADMINISTRADOR. EL HABÍA CONCEBIDO LA IDEA DE SACAR LAS MERCANCIAS POR EL RÍO QUE PASA DENTRO DE LA FÁBRICA...



...COMO EL RÍO ESTABA EN ESAS CONDICIONES CREYERON QUE NADIE SE DARÍA CUENTA. PERO EL JEFE DE PRODUCCIÓN SOSPECHÓ Y SIN QUE EL ADMINISTRADOR LO SUPIERA HIZO LA DENUNCIA.



Y TÚ TAMBIÉN SOSPECHASTE.

¡ST!



¡HOLA, BELLEZA!



¡APARTE DE BUEN POLICIA ERES TAMBIÉN BUEN ACTOR!



TENÍA ÓRDENES DE DEJARLOS IR. SI NO SE HUBIERA FRUSTRADO LA OPERACIÓN.

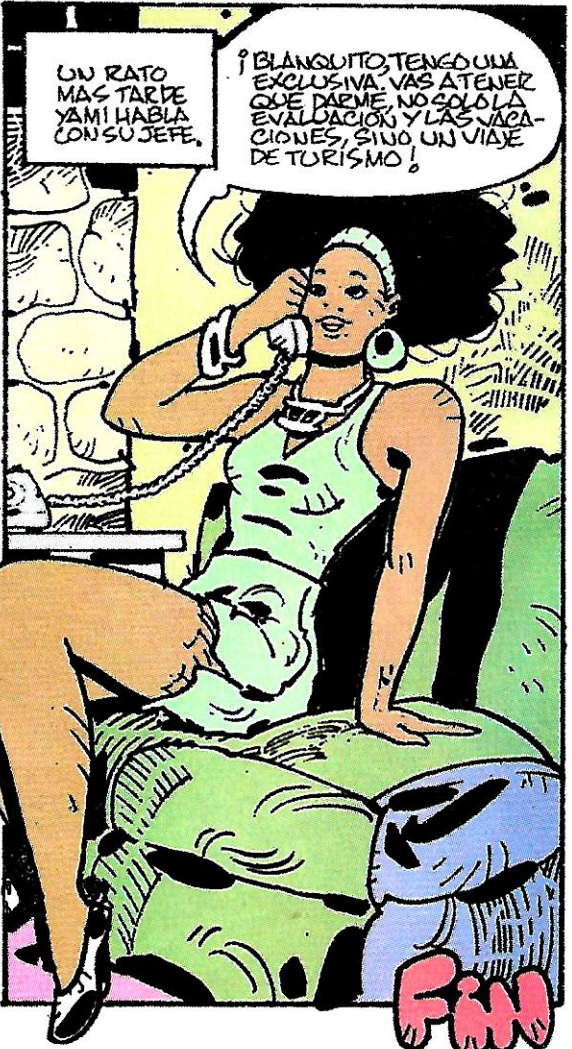

UN RATO MÁS TARDE YAMI HABÍA CON SU JEFE.

¡BLANQUITO, TENGO UNA EXCLUSIVA. VAS A TENER QUE DARMÉ, NO SOLO LA EVALUACIÓN Y LAS VACACIONES, SINO UN VIAJE DE TURISMO!



UN RATO DESPUÉS.

¿NO TE SIENTES MOLESTA?

¡NO, AL CONTRARIO!

LOS COMPAÑEROS TEMIAN QUE SIN DARTÉ CUENTA ECHARAS A PERDER LA OPERACIÓN. SIN EMBARGO CONTRIBUISTE A QUE LOS DELINCUENTES TEMIERAN QUE LOS HABÍAN DESCUBIERTOS Y SE APRESURARON A SACAR TODO EL CARGAMENTO ROBADO. POR ESO VIUO EL OTRO QUE NOS FALTABA.



¡QUE ME AYUDÓ A SOBRECUMPLIR MI TRABAJO, PUES EN LUGAR DE UNO HICE DOS!

FIN



CECILIO AVILES

VAYA, VAYA, ASÍ QUE ME ELIMINASTE.

NO DIGAS ESO. SI FUERA ASÍ NO TE HUBIERA LLAMADO.

SI, PERO LO HAS HECHO A UNA HORA EN QUE YA NADA PUEDO HACER.

YAMI, NECESITO QUE VENGAS.

YAMI

GUIÓN Y DIBUJO:
CECILIO ANILÉS

TÚ ERES LA ÚNICA QUE ME PUEDE SACAR DEL APRIETO EN QUE ESTOY.

ENTRE TANTO...

CREO QUE TE CONVIENE ESTE NEGOCIO DE LAS "FOTOS"...

... PERO RECUERDA QUE ALGUNAS DE ELLAS SON PARA MÍ ...



¡BAH, TÚ SABES QUE CONMIGO NO HAY LIO!



JE, YA LO CREO QUE HARÉ MUY BUENAS FOTOS



MIENTRAS... VAYA, AHORA NO TENGO PELÍCULA DE 400 ASA, SOLO DE 80... TAMPOCO TENGO FLASH Y ALLÁ HAY MUY POCALUZ...



...Y NO PUEDO FALARLE A MI AMIGA ...



...TENDRÉ QUE INVENTAR CON LA PELÍCULA QUE TENGO. LE DEJARÉ UNA NOTA A ROLANDO PARA QUE ME PASE A RECOGER.



UN RATO DESPUÉS...

¡MENOS MAL QUE ME PUDE EMPATAR RÁPIDO CON LA DICHOA GUAGUA!



¡BUENAS TARDES!



¿CUÁL ES EL PROBLEMA QUE TIENES?

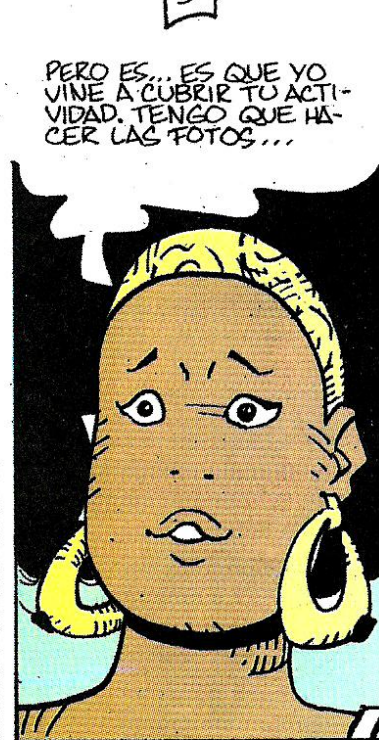
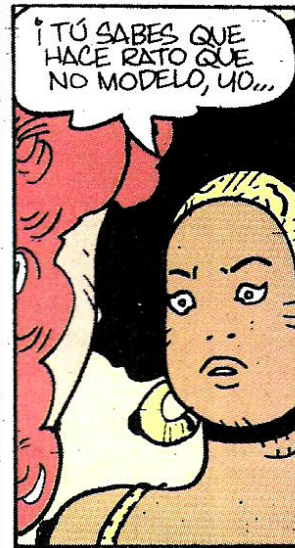

NO SÉ, CON EL NERVIOSISMO Y LA PRESIÓN SE ME OLVIDÓ DE QUE REVISTA ES, PERO LO IMPORTANTE ES QUE ESTÁ AQUÍ Y NOS PUEDE DAR UNA MANO. ASÍ QUE VE A CAMBIARTE QUE YA ESTAMOS EN TIEMPO.

BUENO, PERO DALE MI CÁMARA Y NO DEJES DE DECIRLE QUE LA PELÍCULA QUE TIENE ES DE BO ASA.

¡DESCUIDA!

UN RATO DESPUÉS...

VAMOS A VER COMO SALE ESTO.

TREMENDO CABO ME ESTÁ TIRANDO YAMI. ¿QUE LE HABRÁ SUCEDIDO A TAMARA?

HUM, ¿QUÉ MILAGRO NO USA EL "FLASH"? SEGURO QUE HABRÁ CAMBIADO LA PELÍCULA DE BO ASA QUE TENÍA MI CÁMARA POR UNA DE 400.

¿DE QUÉ REVISTA SERÁ?

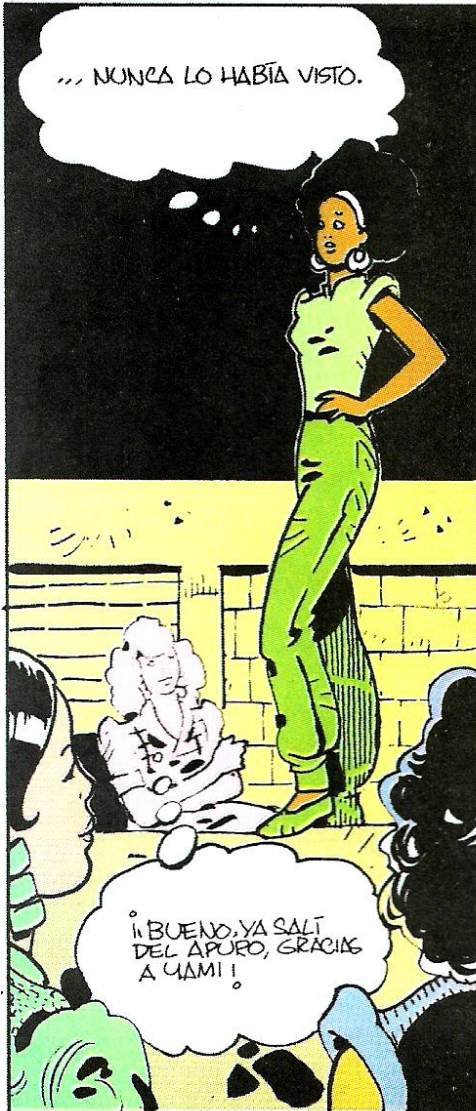



¡ME HAN ROBADO LA CADENA, LOS ARETES Y LA MANILLA DE ORO QUE TENÍA AQUÍ!

¿ESTÁS SEGURA?

6



¡CLARO, LAS DEJÉ COMO DE COSTUMBRE EN EL MALETÍN!



¡ESTO, Y COMO DE COSTUMBRE NO HICISTE CASO A MIS CONSEJOS!



¡TE HE DICHO UNAY MIL VECES QUE NO DEBES TRAER ESAS PRENDAS AQUÍ!



ES QUE SOLAMENTE TAMARA Y YO SABEMOS DÓNDE LAS GUARDO.



PERO TAMARA NO VIÑO HOY. HABRÁ QUE LLAMAR A LA POLICIA.

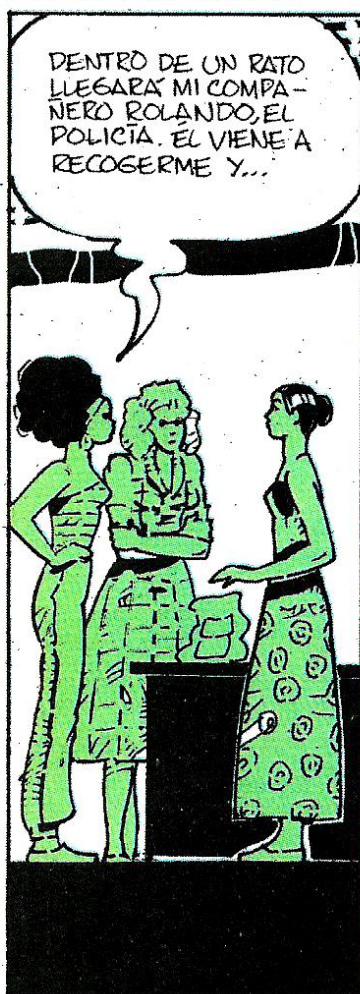

DENTRO DE UN RATO LLEGARÁ MI COMPAÑERO ROLANDO EL POLICIA. EL VIENE A RECOGERME Y...



... OYE, HAY QUE ATAJAR AL FOTOGRAFO ESE...



... ESPÉRENME AQUÍ, Y NO VAYAN A TOCAR NADA MÁS, QUE TENGO UNA CORAZONADA

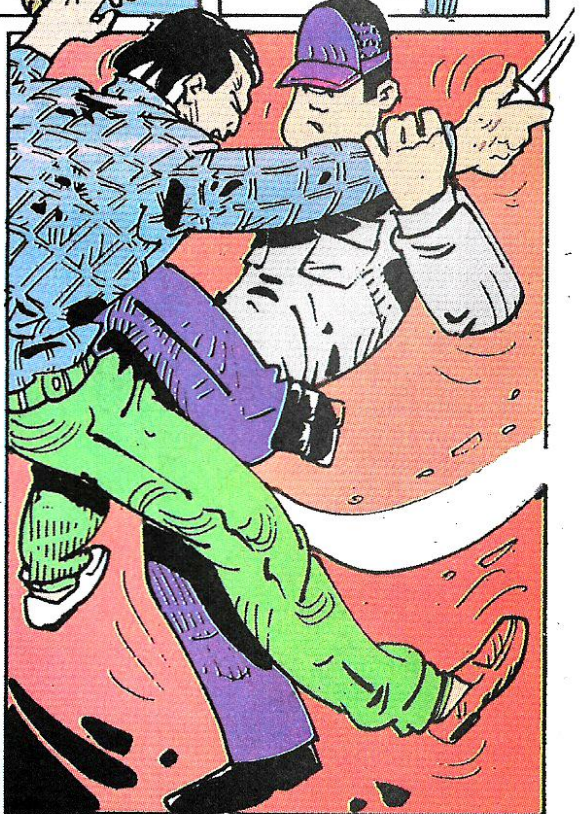
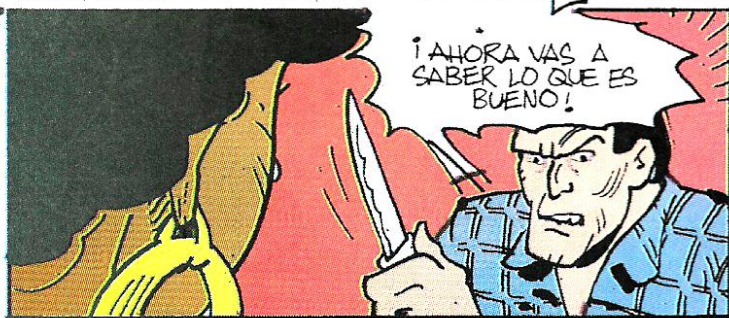



ROLANDO, ESTE INDIVIDUO COMETIÓ UN ROBO CERCA DE AQUÍ, DÉJAME EXPLICARTE ...



AL RATO...
... ESO ES MÁS O MENOS LO QUE ME IMAGINO QUE OCURRIÓ.



PRONTO SABREMOS LA VERDAD.



AL RATO...

BUENO, YA TODO ESTA ACLARADO.

QUIÉN IBA A PENSAR QUE TAMARA ESTABA EN COMBINACION CON ESE FOTOGRAFO, JAMI, ¿ COMO FUE QUE LO DESCUBRISTE ?



HOM, POR DEDUCCION E INTUICION...



... UN PROFESIONAL SABE QUE CON BO ASA EN UN LUGAR CON TAN POCOA LUZ NADA SE PUEDE HACER ...

... A NO SER QUE ACUDA A OTROS RECURSOS COMO SON EL USO DEL "FLASH" O LA MODIFICACION DE LAS VELOCIDADES. PERO EL NO EMPLEO NINGUNO, Y CUANDO LE PREGUNTE COMO HABIA HECHO LAS FOTOS SE PUSO MEDIO NERVIOSO ...



... ADEMÁS, YO CONOZCO A CASI TODOS LOS FOTOPREPOR- TEROS DE REVISTAS Y A ÉSTE NUNCA LO HABIA VISTO.

FIN





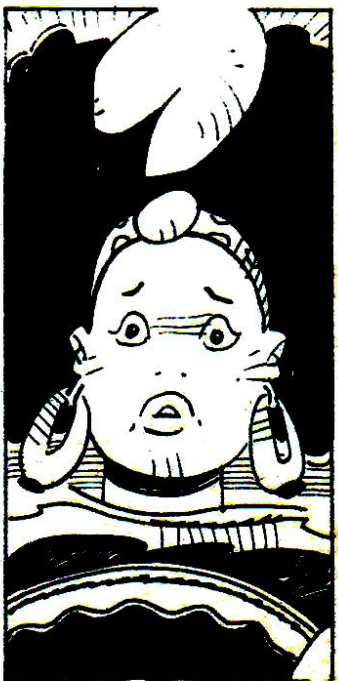

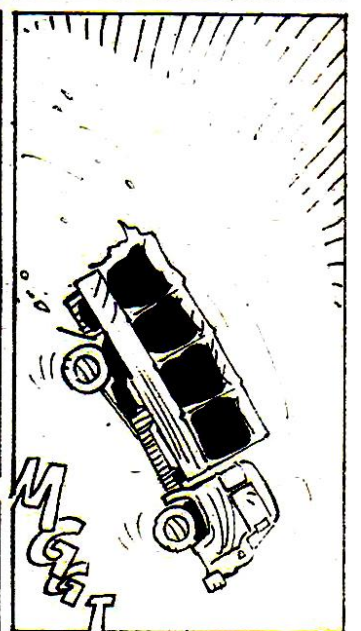











LOS VOY A CAZAR COMO A DOS RATONES.



ENTRE-TANTO...



VAYA CARA... VOY ENTENDIENDO...



EL CAMIÓN...



ESTABA VACÍO...



TENEMOS QUE APURARNOS.



YA SE QUIENES ATACARON A JULIAN.



AHÍ VIENE UNO.



¡DESGRACIA!



TE VOY A MATAR...



¡ALTO!

¡ESTÁN DETENIDOS!



UN RATO MÁS TARDE...

TODO FUE MUY BIEN PLANEA-
DO POR EL ADMINISTRADOR. EL
QUITÓ DEL MEDIO A JULIAN
APROVECHANDO QUE ESTE
BEBIA DE VEZ EN CUANDO.
PARA PONER AL OTRO
CHOFER.

QUE ERA SU COMPLICI...



ELLOS DOS IDEARON EL
ROBO DE LA CARGA DE CAFÉ
A COSTA DE LA VIDA DEL
AYUDANTE. PERO FALLA-
RON AL ATACAR A JULIAN
PENSANDO QUE ESTE LOS
HABIA DESCUBIERTO. UNO
DE ELLOS DEJO HUELLAS
DE FANGO ROJO. ERA EL
CHOFER...



...ESTE SE EMBARRÓ LOS ZAPATOS CUANDO
ESCONDIO EL ROBO EN UN LUGAR DONDE
HABIA TIERRA ROJA Y LLOVIDO. ME
LLAMÓ LA ATENCIÓN PORQUE POR AQUI
NO HAY TIERRA ROJA Y ADEMAS TAMPOCO
HABIA LLOVIDO. OBSERVE QUE SU
AYUDANTE TENIA LOS ZAPATOS LIMPOS.

FIN



¡Ahora que ya nos hemos conocido, te invito a dibujar!

Utiliza como modelo mi propia cabeza. Te auxiliarás de un rectángulo que deberás dividir en cuatro partes iguales en forma horizontal y en dos mitades con una línea vertical. En la página siguiente encontrarás la explicación gráfica del orden de los pasos que debes tener en cuenta para lograr un buen resultado.

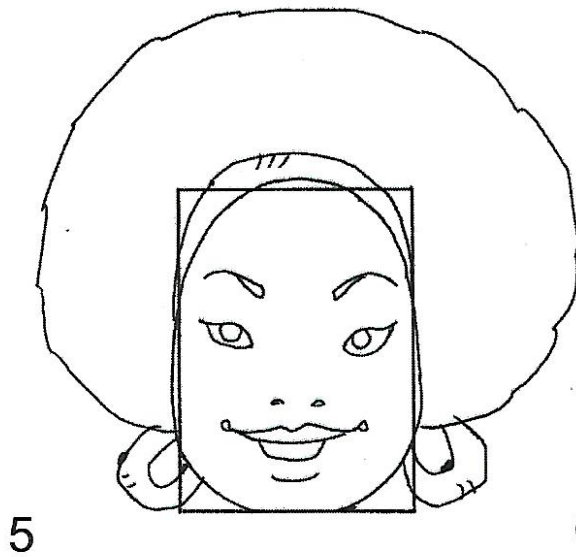
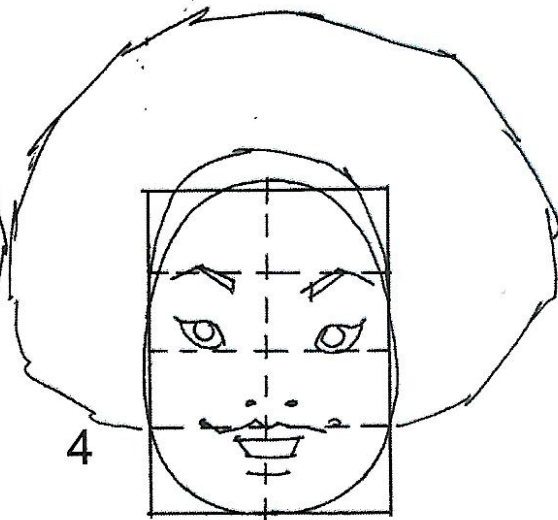
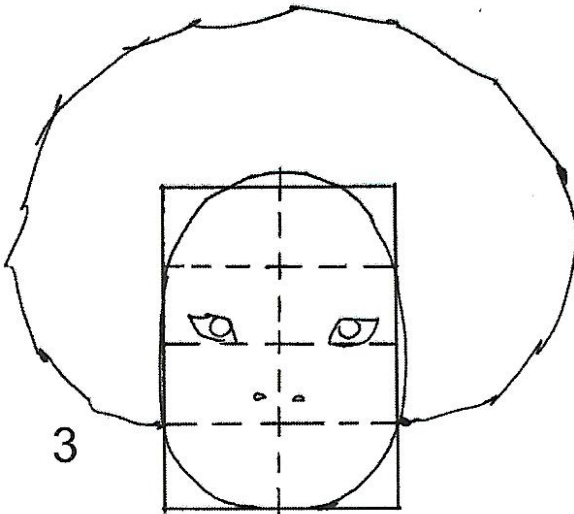
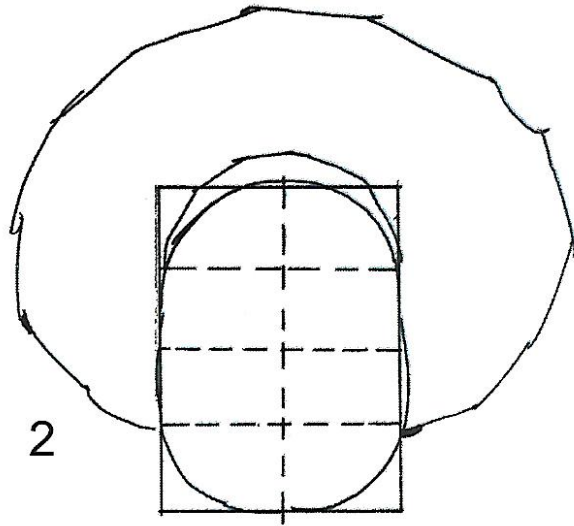
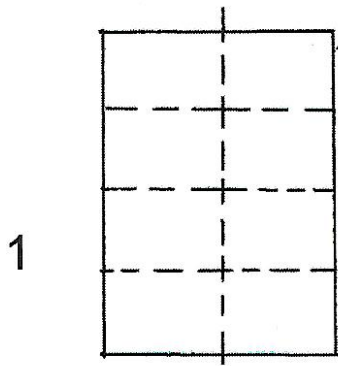



Como ya has aprendido a dibujar mi cabeza, te propongo que hagas lo que los artistas de la historieta y el dibujo animado reconocen como UNA CARTA DE EXPRESIÓN.





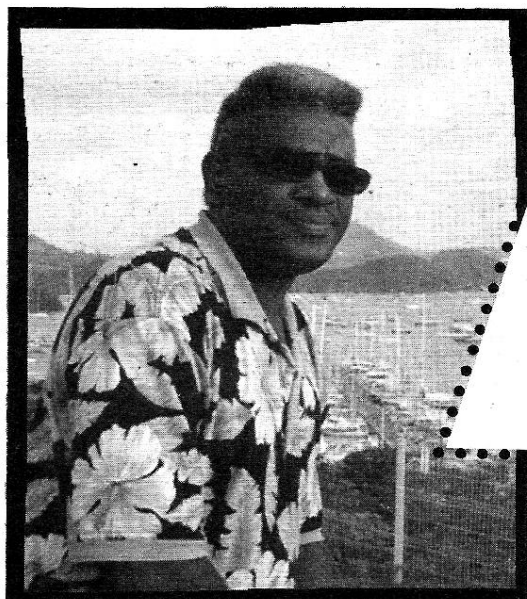

Cecilio Avilés Montalvo (1944). Es Licenciado en Historia del Arte de la Universidad de La Habana, graduado en Pintura y Modelado de la Academia de Bellas Artes de San Alejandro. Laboró como historietista y Director Artístico de *Pionero* en la década de los ochenta. Fue realizador de programas de la Escuela de Dirección de Televisión del ICRT. Estudió música y armonía en la Academia Ignacio Cervantes. Actualmente expone sus obras en Cuba y el extranjero y se dedica a la música y a las Artes Plásticas.

Yamy es una joven fotoreportera que alterna su labor como periodista gráfica con el modelaje, la pintura y la música. En el desempeño de estas funciones siempre se ve enredada en diversas aventuras de las que logra salir airosa gracias a su inteligencia y valentía.



978-959-259-303-9



Pablo de la Torre
Editorial